

Unilin Insulation UK Ltd  
Liscarton Industrial Estate  
Kells Road, Navan  
Co Meath C15 NP79  
Ireland

Tel: 0371 222 1033  
e-mail: info.ui@unilin.com  
website: www.unilininsulation.co.uk



## Agrément Certificate

23/6997

Product Sheet 1 Issue 2

### UNILIN THIN-R INSULATION

### UNILIN THIN-R THERMAL LINER BOARDS (XT/TL AND XT/TL-MF)

This Agrément Certificate Product Sheet<sup>(1)</sup> relates to Unilin Thin-R Thermal Liner Boards (XT/TL and XT/TL-MF), comprising rigid polyisocyanurate (PIR) foam boards bonded to plasterboard, for use as an insulating dry lining to masonry (solid or cavity) walls and to horizontal or sloped timber roof ceilings, in new and existing domestic buildings, with height restrictions.

(1) Hereinafter referred to as 'Certificate'.

#### The assessment includes

##### Product factors:

- compliance with Building Regulations
- compliance with additional regulatory or non-regulatory information where applicable
- evaluation against technical specifications
- assessment criteria and technical investigations
- uses and design considerations

##### Process factors:

- compliance with Scheme requirements
- installation, delivery, handling and storage
- production and quality controls
- maintenance and repair

##### Ongoing contractual Scheme elements†:

- regular assessment of production
- formal 3-yearly review



#### KEY FACTORS ASSESSED

- Section 1. Mechanical resistance and stability
- Section 2. Safety in case of fire
- Section 3. Hygiene, health and the environment
- Section 4. Safety and accessibility in use
- Section 5. Protection against noise
- Section 6. Energy economy and heat retention
- Section 7. Sustainable use of natural resources
- Section 8. Durability

The BBA has awarded this Certificate to the company named above for the products described herein. These products have been assessed by the BBA as being fit for their intended use provided they are installed, used and maintained as set out in this Certificate.

On behalf of the British Board of Agrément

Date of Second issue: 25 February 2026  
Originally certified on 25 September 2024

Hardy Giesler  
Chief Executive Officer

*This BBA Agrément Certificate is issued under the BBA's Inspection Body accreditation to ISO/IEC 17020. Sections marked with † are not issued under accreditation.*

*The BBA is a UKAS accredited Inspection Body (No. 4345), Certification Body (No. 0113) and Testing Laboratory (No. 0357).*

*Readers MUST check that this is the latest issue of this Agrément Certificate by either referring to the BBA website or contacting the BBA directly.*

*The Certificate must be read in full as it may be misleading to read clauses in isolation.*

*Any photographs are for illustrative purposes only, do not constitute advice and should not be relied upon.*

#### British Board of Agrément

1<sup>st</sup> Floor, Building 3, Hatters Lane  
Croxley Park, Watford  
Herts WD18 8YG

©2026

tel: 01923 665300  
clientservices@bbacerts.co.uk  
www.bbacerts.co.uk

## SUMMARY OF ASSESSMENT AND COMPLIANCE

This section provides a summary of the assessment conclusions; readers should refer to the later sections of this Certificate for information about the assessments carried out.

### Compliance with Regulations

Having assessed the key factors, the opinion of the BBA is that Unilin Thin-R Thermal Liner Boards (XT/TL and XT/TL-MF), if installed, used and maintained in accordance with this Certificate, can satisfy or contribute to satisfying the relevant requirements of the following Building Regulations:



#### The Building Regulations 2010 (England and Wales) (as amended)

<b>Requirement:</b> B2(1)	<b>Internal fire spread (linings)</b>
Comment:	The products are unrestricted by this Requirement. See section 2 of this Certificate.
<b>Requirement:</b> B3(4)	<b>Internal fire spread (structure)</b>
Comment:	The products can contribute to satisfying this Requirement. See section 2 of this Certificate.
<b>Requirement:</b> B4(1)	<b>External fire spread</b>
Comment:	The products are restricted by this Requirement. See section 2 of this Certificate.
<b>Requirement:</b> C2(c)	<b>Resistance to moisture</b>
Comment:	The products can contribute to satisfying this Requirement. See section 3 of this Certificate.
<b>Requirement:</b> L1(a)(i)	<b>Conservation of fuel and power</b>
Comment:	The products can contribute to satisfying this Requirement; however, compensating fabric measures may be required. See section 6 of this Certificate.
<b>Regulation:</b> 7(1)	<b>Materials and workmanship</b>
Comment:	The products are acceptable. See sections 8 and 9 of this Certificate.
<b>Regulation:</b> 7(2)	<b>Materials and workmanship</b>
Comment:	The products are restricted by this Regulation. See section 2 of this Certificate.
<b>Regulation:</b> 25B	<b>Nearly zero-energy requirements for new buildings</b>
<b>Regulation:</b> 26	<b>CO<sub>2</sub> emission rates for new buildings</b>
<b>Regulation:</b> 26A	<b>Fabric energy efficiency rates (applicable to England only)</b>
<b>Regulation:</b> 26A	<b>Primary energy rates for new buildings (applicable to Wales only)</b>
<b>Regulation:</b> 26B	<b>Fabric performance values for new dwellings</b>
<b>Regulation:</b> 26C	<b>Target primary energy rates for new buildings (applicable to England only)</b>
<b>Regulation:</b> 26C	<b>Minimum energy efficiency rating (applicable to Wales only)</b>
Comment:	The products can contribute to satisfying these Regulations; however, compensating fabric/service measures may be required. See section 6 of this Certificate.



#### The Building (Scotland) Regulations 2004 (as amended)

<b>Regulation:</b> 8(1)	<b>Fitness and durability of materials and workmanship</b>
Comment:	The products are acceptable. See sections 8 and 9 of this Certificate.
<b>Regulation:</b> 8(3)	<b>Fitness and durability of materials and workmanship</b>
Comment:	The products are restricted by this Regulation. See section 2 of this Certificate.

<b>Regulation:</b>	<b>9</b>	<b>Building standards – construction</b>
Standard:	2.4	Cavities
Comment:		The products can contribute to satisfying this Standard with reference to clause 2.4.2 <sup>(1)</sup> . See section 2 of this Certificate.
Standard:	2.5	Internal linings
Comment:		The products are unrestricted by this Standard, with reference to clause 2.5.1 <sup>(1)</sup> . See section 2 of this Certificate.
Standard:	2.6	Spread to neighbouring buildings
Comment:		The products are restricted by this Standard, with reference to clause 2.6.5 <sup>(1)</sup> . See section 2 of this Certificate.
Standard:	3.15	Condensation
Comment:		The products can contribute to satisfying this Standard, with reference to clauses 3.15.1 <sup>(1)</sup> , 3.15.3 <sup>(1)</sup> , 3.15.4 <sup>(1)</sup> , 3.15.5 <sup>(1)</sup> , 3.15.6 <sup>(1)</sup> and 3.15.7 <sup>(1)</sup> . See section 3 of this Certificate.
Standard:	6.1(b)(c)	Energy demand
Comment:		The products can contribute to satisfying this Standard, with reference to clause 6.1.1 <sup>(1)</sup> ; however, compensating fabric/service measures may be required. See section 6 of this Certificate.
Standard:	6.2	Building insulation envelope
Comment:		The products can contribute to satisfying this Standard, with reference to clauses 6.2.1 <sup>(1)</sup> , 6.2.3 <sup>(1)</sup> and 6.2.6 <sup>(1)</sup> to 6.2.12 <sup>(1)</sup> ; however, compensating fabric measures may be required. See section 6 of this Certificate.
Standard:	7.1(a)(b)	Statement of sustainability
Comment:		The products can contribute to satisfying the relevant requirements of Regulation 9, Standards 1 to 6, and therefore will contribute to a construction meeting a bronze level of sustainability as defined in this Standard. In addition, the products can, in some cases, contribute to a construction meeting a higher level of sustainability as defined in this Standard, with reference to clauses 7.1.4 <sup>(1)</sup> , 7.1.6 <sup>(1)</sup> and 7.1.7 <sup>(1)</sup> . See section 6 of this Certificate.
<b>Regulation:</b>	<b>12</b>	<b>Building standards – conversion</b>
Comment:		Comments made in relation to the products under Regulation 9, Standards 1 to 6, also apply to this Regulation, with reference to clause 0.12.1 <sup>(1)</sup> and Schedule 6 <sup>(1)</sup> .

(1) Technical Handbook (Domestic).



## The Building Regulations (Northern Ireland) 2012 (as amended)

<b>Regulation:</b>	<b>23(1)(a)(i)</b>	<b>Fitness of materials and workmanship</b>
Comment:	<b>(iii)(b)(i)(ii)</b>	The products are acceptable. See sections 8 and 9 of this Certificate.
<b>Regulation:</b>	<b>23(2)</b>	<b>Fitness of materials and workmanship</b>
Comment:		The products are restricted by this Regulation. See section 2 of this Certificate.
<b>Regulation:</b>	<b>29</b>	<b>Condensation</b>
Comment:		The products can contribute to satisfying this Regulation. See section 3 of this Certificate.
<b>Regulation:</b>	<b>34(a)(b)</b>	<b>Internal fire spread – linings</b>
Comment:		The products are unrestricted by this Regulation. See section 2 of this Certificate

<b>Regulation:</b>	<b>35(1)</b>	<b>Internal fire spread – structure</b>
<b>Comment:</b>		The products are restricted by this Regulation. See section 2 of this Certificate.
<b>Regulation:</b>	<b>35(4)</b>	<b>Internal fire spread – structure</b>
<b>Comment:</b>		The products can contribute to satisfying this Regulation. See section 2 of this Certificate.
<b>Regulation:</b>	<b>36(a)</b>	<b>External fire spread</b>
<b>Comment:</b>		The products are restricted by this Regulation. See section 2 of this Certificate.
<b>Regulation:</b>	<b>39(a)(i)</b>	<b>Conservation measures</b>
<b>Comment:</b>		The products can contribute to satisfying this Regulation; however, compensating fabric measures may be required. See section 6 of this Certificate.
<b>Regulation:</b>	<b>40(2)</b>	<b>Target carbon dioxide emission rate</b>
<b>Regulation:</b>	<b>43(1)(2)</b>	<b>Renovation of thermal elements</b>
<b>Regulation:</b>	<b>43B</b>	<b>Nearly zero-energy requirements for new buildings</b>
<b>Comment:</b>		The products can contribute to satisfying these Regulations; however, compensating fabric/service measures may be required. See section 6 of this Certificate.

## Fulfilment of requirements

### NHBC Standards 2026

In the opinion of the BBA, Unilin Thin-R Thermal Liner Boards (XT/TL and XT/TL-MF), if installed, used and maintained in accordance with this Certificate, can satisfy or contribute to satisfying the relevant requirements in relation to *NHBC Standards*, Chapters 6.1 *External masonry walls* and 9.2 *Wall and ceiling finishes*.

The opinion of the BBA does not amount to any endorsement or approval by the NHBC and does not in any way guarantee that the NHBC will approve such a product / system as compliant with the NHBC Technical Requirements and Standards.

## Fulfilment of Requirements

The BBA has judged Unilin Thin-R Thermal Liner Boards (XT/TL and XT/TL-MF) to be satisfactory for use as described in this Certificate. The products have been assessed for use as insulating dry lining to masonry (solid or cavity) walls and to horizontal or sloped timber roof ceilings, in new and existing domestic buildings, with height restrictions.

## ASSESSMENT

### Product description and intended use

The Certificate holder provided the following description for the products under assessment. Unilin Thin-R Thermal Liner Boards (XT/TL and XT/TL-MF) consist of:

- Unilin Thin-R (XT/TL) — a rigid PIR foam board, with a Kraft paper facing on both sides, bonded to a 12.5 mm gypsum plasterboard on one side
- Unilin Thin-R (XT/TL-MF) — a rigid PIR foam board, with a composite foil facing on both sides, bonded to a 12.5 mm gypsum plasterboard on one side.

The products have the nominal characteristics given in Table 1.

*Table 1 Nominal characteristics*

Characteristic (unit)	Value	
	Unilin Thin-R (XT/TL)	Unilin Thin-R (XT/TL-MF)
Length (mm)	2400 and 2438	2400 and 2438
Width (mm)	1200	1200
Insulation thickness (mm)	25 to 80	25 to 100
Plasterboard thickness (mm)	12.5	12.5
Facing	Kraft paper	Composite foil
Edge profile	Square insulation with tapered plasterboard	Square insulation with tapered plasterboard

### Ancillary Items

The Certificate holder recommends the following ancillary items for use with the products, but these materials have not been assessed by the BBA and are outside the scope of this Certificate:

- timber battens
- metal furrings
- damp-proof course (DPC)
- breather membrane
- dry lining adhesive compound
- dry wall screws or plasterboard nails
- nailable plugs
- air and vapour control layer (AVCL)
- edge and corner beads
- scrim tape and joining compound or plaster for skim coat.

### Applications

The products are intended for internal use on external solid or cavity masonry walls (including clay and calcium silicate bricks, concrete blocks and natural and reconstituted stone blocks) and horizontal or sloped timber roof ceilings, in new and existing domestic buildings.

The boards may be installed:

- by direct bonding to the wall using plaster adhesive dabs (XT/TL)
- by mechanical fixing either directly to the wall onto timber battens or metal furring systems, or to the underside of timber rafters or ceiling joists (XT/TL-MF).

## **Product assessment – key factors**

The product was assessed for the following key factors, and the outcome of the assessments is shown below. Conclusions relating to the Building Regulations apply to the whole of the UK unless otherwise stated.

### **1 Mechanical resistance and stability**

Data were assessed for the following characteristic.

#### 1.1 Mechanical properties

1.1.1 The products were tested for mechanical properties, and the results are given in Table 2.

**Table 2 Compressive strength and adhesion/cohesion**

Product assessed	Assessment method	Requirement	Result
Insulation component of Unilin Thin-R Thermal Liner Boards (XT/TL and XT/TL-MF)	Compressive strength to BS EN 826 : 1996	Value achieved	≥ 140 kPa
Unilin Thin-R Thermal Liner Boards (XT/TL and XT/TL-MF)	Bond strength to BS EN 13950 : 2014	> 0.017 MPa	Pass

1.1.2 On the basis of data assessed, the products have adequate mechanical properties.

## 2 Safety in case of fire

Data were assessed for the following characteristics.

### 2.1 Reaction to fire

2.1.1 The products were tested for reaction to fire, and the classification is given in Table 3.

**Table 3 Reaction to fire classification**

Product assessed	Assessment method	Requirement	Result <sup>(1)</sup>
Unilin Thin-R Thermal Liner Boards (XT/TL and XT/TL-MF) fixed to gypsum plasterboard with urethane adhesive	BS EN 13501-1 : 2018	Value achieved	B-s1, d0

(1) Efectis UK/Ireland Limited, classification report reference EUI-20-000379, dated 4 May 2021, copies available from the Certificate holder on request. The classification is valid for:

- Plasterboard thickness ≥ 12.5 mm
- Insulation thickness ≤ 100 mm
- Insulation density ≤ 32 kg·m<sup>-3</sup>
- Panels adhered to a substrate using gypsum-based adhesive as specified in BS EN 14496 : 2017 and fixed mechanically, directly to a substrate or to a wood or metal framework, with the PIR facing the substrate/framework
- Joints between adjoining composite panels fully filled with jointing material as specified in BS EN 13963 : 2014.

2.1.2 The Certificate holder has not declared a reaction to fire classification to BS EN 13501-1 : 2018 for the reverse side (facing into the cavity) of the insulation component.

2.1.3 On the basis of data assessed, the products will be restricted in use under the documents supporting the national Building Regulations.

2.1.4 In England and Wales, the products must not be used on external walls of residential buildings with a storey 11 m or more in height or on other buildings with a storey 18 m or more in height.

2.1.5 In Scotland, the products must not be used 1m or less from a relevant boundary on buildings with a story height more than 18m from the ground.

2.1.6 In Northern Ireland, the products must not be used on buildings with a storey 18 m or more in height.

2.1.7 Designers must refer to the relevant national Building Regulations and guidance for detailed conditions of use, particularly in respect of requirements for substrate fire performance, cavity closers and barriers, fire stopping of service penetrations and combustibility limitations for other materials and components used in the overall wall construction.

## 2.2 Resistance to fire

Where the products are incorporated in a wall construction where fire resistance is required by the documents supporting the national Building Regulations, the fire resistance must be confirmed by a suitably experienced and competent individual.

## 3 Hygiene, health and the environment

Data were assessed for the following characteristics.

### 3.1 Water vapour permeability

3.1.1 The products were tested/assessed for water vapour resistivity/resistance, and the results are given in Table 4.

*Table 4 Water vapour resistivity/resistance*

Product assessed	Assessment method	Requirement	Result
PIR insulation core	BS EN 12086 : 2013	Value achieved	272 MN·s·g <sup>-1</sup> ·m <sup>-1</sup>
Composite foil facing			940 MN·s·g <sup>-1</sup>
Plasterboard	BS EN ISO 10456 : 2007	Declared value	50 MN·s·g <sup>-1</sup> ·m <sup>-1</sup>
Kraft paper facing			1000 MN·s·g <sup>-1</sup>

3.1.2 For the purpose of assessing the risk of condensation, the water vapour resistivity/resistance values may be taken as stated in Table 4.

### 3.2 Condensation

3.2.1 The BBA has assessed the products for the risk of interstitial condensation, and the following must be implemented.

3.2.2 Where calculations to BS 5250 : 2021 indicate a risk of persistent interstitial condensation, a site-specific dynamic analysis to BS EN 15026 : 2023 must be carried out.

3.2.3 All joints between the products must be sealed in accordance with the Certificate holder's instructions (see Annex A of this Certificate), to ensure adequate resistance to water vapour transmission.

## 4 Safety and accessibility in use

Not applicable.

## 5 Protection against noise

Not applicable.

## 6 Energy economy and heat retention

Data were assessed for the following characteristics.

### 6.1 Thermal conductivity

The insulation core and the plasterboard were tested/assessed for thermal conductivity, and the results are given in Table 5.

*Table 5 Thermal conductivity*

Product assessed	Assessment method	Requirement	Result
PIR insulation core	BS EN 13165 : 2012	Declared value ( $\lambda_D$ )	0.022 W·m <sup>-1</sup> ·K <sup>-1</sup>
Plasterboard	BS EN ISO 10456 : 2007	Declared value	0.25 W·m <sup>-1</sup> ·K <sup>-1</sup>

## 6.2 Thermal performance

The facings were tested/assessed for emissivity, and the results are given in Table 6.

**Table 6 Emissivity**

Product assessed	Assessment method	Requirement	Result
Composite foil facing	BS EN 16012 : 2012	Declared value	0.05
Kraft paper facing	BS EN ISO 6946 : 2017	Design value	0.9

## 6.3 Conservation of fuel and power

6.3.1 The U value of a completed wall or roof will depend on the insulation thickness, number and type of fixings and its structure. Example U values are given in Tables 7 to 9 of this Certificate.

**Table 7 Example U values — insulated dry lining to solid masonry wall**

Target U value ( $W \cdot m^{-2} \cdot K^{-1}$ )	Insulation thickness (mm)	
	Unilin Thin-R (XT/TL) Adhesively fixed <sup>(1)</sup> (dots and dabs)	Unilin Thin-R (XT/TL-MF) Mechanically fixed <sup>(2)</sup> (to timber battens)
0.13	— <sup>(3)</sup>	— <sup>(3)</sup>
0.15	— <sup>(3)</sup>	— <sup>(3)</sup>
0.17	— <sup>(3)</sup>	— <sup>(3)</sup>
0.18	— <sup>(3)</sup>	— <sup>(3)</sup>
0.21	— <sup>(3)</sup>	90
0.26	70	70
0.28	65	60
0.30	60	55
0.35	50	45

- (1) Wall construction, external to internal: 215 mm solid brickwork ( $\lambda = 0.77 W \cdot m^{-1} \cdot K^{-1}$ ) bridged by mortar ( $\lambda = 0.94 W \cdot m^{-1} \cdot K^{-1}$ , 17.3% fraction); 15 mm plaster dabs cavity ( $R = 0.171 m^2 \cdot K^{-1} \cdot W^{-1}$ ) with 20% adhesive coverage ( $\lambda = 0.43 W \cdot m^{-1} \cdot K^{-1}$ ); XT/TL insulation adhesively fixed, including 3 fully penetrating supplementary steel fixings per board ( $\lambda = 50 W \cdot m^{-1} \cdot K^{-1}$ , 1.04 fixings per  $m^2$ , 12.5 mm<sup>2</sup> cross-section); 12.5 mm plasterboard ( $\lambda = 0.25 W \cdot m^{-1} \cdot K^{-1}$ ).
- (2) Wall construction, external to internal: 215 mm solid brickwork ( $\lambda = 0.77 W \cdot m^{-1} \cdot K^{-1}$ ) bridged by mortar ( $\lambda = 0.94 W \cdot m^{-1} \cdot K^{-1}$ , 17.3% fraction); low emissivity ( $\epsilon = 0.05$ ) airspace bridged by 22 mm deep timber battens ( $\lambda = 0.13 W \cdot m^{-1} \cdot K^{-1}$ , 11.8% fraction); XT/TL-MF insulation mechanically fixed with 12 fully penetrating steel fixings per board ( $\lambda = 50 W \cdot m^{-1} \cdot K^{-1}$ , 4.17 fixings per  $m^2$ , 12.5 mm<sup>2</sup> cross-section); 12.5 mm plasterboard ( $\lambda = 0.25 W \cdot m^{-1} \cdot K^{-1}$ ).
- (3) See section 6.3.3.

**Table 8 Example U values — insulated dry lining to existing insulated masonry cavity wall**

Target U value (W·m <sup>-2</sup> ·K <sup>-1</sup> )	Insulation thickness (mm)	
	Unilin Thin-R (XT/TL) Adhesively fixed <sup>(1)</sup> (dots and dabs)	Unilin Thin-R (XT/TL-MF) Mechanically fixed <sup>(2)</sup> (to timber battens)
0.13	— <sup>(4)</sup>	95
0.15	75	75
0.17	60	55
0.18	50	45
0.21	35	30
0.26	25	25
0.28	25	25
0.30	25	25
0.35	0 <sup>(3)</sup>	0 <sup>(3)</sup>

- (1) Wall construction, external to internal: 102.5 mm solid brickwork ( $\lambda = 0.77 \text{ W}\cdot\text{m}^{-1}\cdot\text{K}^{-1}$ ) bridged by mortar ( $\lambda = 0.94 \text{ W}\cdot\text{m}^{-1}\cdot\text{K}^{-1}$ , 17.3% fraction); 100 mm cavity fully filled with polystyrene beads ( $\lambda_D = 0.038 \text{ W}\cdot\text{m}^{-1}\cdot\text{K}^{-1}$ ) bridged with mild steel double triangle ties ( $\lambda = 50 \text{ W}\cdot\text{m}^{-1}\cdot\text{K}^{-1}$ , 2.50 fixings per m<sup>2</sup>, 12.5 mm<sup>2</sup> cross-section); 100 mm dense blockwork ( $\lambda = 1.13 \text{ W}\cdot\text{m}^{-1}\cdot\text{K}^{-1}$ ) bridged by mortar ( $\lambda = 0.88 \text{ W}\cdot\text{m}^{-1}\cdot\text{K}^{-1}$ , 6.7% fraction); 15 mm plaster dabs cavity ( $R = 0.171 \text{ m}^2\cdot\text{K}^{-1}\cdot\text{W}^{-1}$ ) with 20% adhesive coverage ( $\lambda = 0.43 \text{ W}\cdot\text{m}^{-1}\cdot\text{K}^{-1}$ ); XT/TL insulation adhesively fixed, including 3 fully penetrating supplementary steel fixings per board ( $\lambda = 50 \text{ W}\cdot\text{m}^{-1}\cdot\text{K}^{-1}$ , 1.04 fixings per m<sup>2</sup>, 12.5 mm<sup>2</sup> cross-section); 12.5 mm plasterboard ( $\lambda = 0.25 \text{ W}\cdot\text{m}^{-1}\cdot\text{K}^{-1}$ ).
- (2) Wall construction, external to internal: 102.5 mm solid brickwork ( $\lambda = 0.77 \text{ W}\cdot\text{m}^{-1}\cdot\text{K}^{-1}$ ) bridged by mortar ( $\lambda = 0.94 \text{ W}\cdot\text{m}^{-1}\cdot\text{K}^{-1}$ , 17.3% fraction); 100 mm cavity fully filled with polystyrene beads ( $\lambda_D = 0.038 \text{ W}\cdot\text{m}^{-1}\cdot\text{K}^{-1}$ ) bridged with mild steel double triangle ties ( $\lambda = 50 \text{ W}\cdot\text{m}^{-1}\cdot\text{K}^{-1}$ , 2.50 fixings per m<sup>2</sup>, 12.5 mm<sup>2</sup> cross-section); 100 mm dense blockwork ( $\lambda = 1.13 \text{ W}\cdot\text{m}^{-1}\cdot\text{K}^{-1}$ ) bridged by mortar ( $\lambda = 0.88 \text{ W}\cdot\text{m}^{-1}\cdot\text{K}^{-1}$ , 6.7% fraction); low emissivity ( $\epsilon = 0.05$ ) airspace bridged by 22 mm deep timber battens ( $\lambda = 0.13 \text{ W}\cdot\text{m}^{-1}\cdot\text{K}^{-1}$ , 11.8% fraction); XT/TL-MF insulation mechanically fixed with 12 fully penetrating steel fixings per board ( $\lambda = 50 \text{ W}\cdot\text{m}^{-1}\cdot\text{K}^{-1}$ , 4.17 fixings per m<sup>2</sup>, 12.5 mm<sup>2</sup> cross-section); 12.5 mm plasterboard ( $\lambda = 0.25 \text{ W}\cdot\text{m}^{-1}\cdot\text{K}^{-1}$ ).
- (3) Achieves the U value without the insulated dry lining.
- (4) See section 6.3.3.

**Table 9 Example U values — insulated dry lining to warm pitched roof**

Target U value (W·m <sup>-2</sup> ·K <sup>-1</sup> )	Insulation thickness (mm)	
	Unilin Thin-R (XT/TL-MF) Mechanically fixed to timber rafters/ceiling joists <sup>(1)</sup>	
0.09	— <sup>(2)</sup>	
0.11	— <sup>(2)</sup>	
0.12	— <sup>(2)</sup>	
0.13	— <sup>(2)</sup>	
0.15	100	
0.16	90	
0.18	75	
0.20	65	

- (1) Pitched roof construction: Concrete tiles and timber battens; breather membrane; 50 mm fully-ventilated cavity; 100 mm mineral wool insulation ( $\lambda_D = 0.040 \text{ W}\cdot\text{m}^{-1}\cdot\text{K}^{-1}$ ) fitted between 50 mm x 150 mm timber rafters at 400 mm centres ( $\lambda = 0.13 \text{ W}\cdot\text{m}^{-1}\cdot\text{K}^{-1}$ , 12.5% fraction); XT/TL-MF insulation mechanically fixed with 12 fully penetrating steel fixings per board ( $\lambda = 50 \text{ W}\cdot\text{m}^{-1}\cdot\text{K}^{-1}$ , 4.17 fixings per m<sup>2</sup>, 12.5 mm<sup>2</sup> cross-section); 12.5 mm plasterboard ( $\lambda = 0.25 \text{ W}\cdot\text{m}^{-1}\cdot\text{K}^{-1}$ ).
- (2) See section 6.3.3.

6.3.2 On the basis of data assessed, the products can contribute towards a construction satisfying the national Building Regulations in respect of energy economy and heat retention.

6.3.3 For improved energy or carbon savings, designers must consider appropriate fabric and/or service measures.

## 7 Sustainable use of natural resources

Not applicable.

## 8 Durability

8.1 The potential mechanisms for degradation and the known performance characteristics of the materials in these products were assessed.

8.2 Specific test data were assessed as given in Table 10.

*Table 10 Dimensional stability*

Product assessed	Assessment method	Requirement	Result
Unilin Thin-R Thermal Liner Boards (XT/TL and XT/TL-MF)	BS EN 1604 : 2013 (70°C and 90-100% RH for 48 hours)	Length and width ≤ 1% change Thickness ≤ 4% change	Pass

### 8.3 Service life

Under normal service conditions the products will have a life equivalent to the building in which they are incorporated, provided they are designed, installed and maintained in accordance with this Certificate and the Certificate holder's instructions.

## PROCESS ASSESSMENT

Information provided by the Certificate holder was assessed for the following factors:

## 9 Design, installation, workmanship and maintenance

### 9.1 Design

9.1.1 The design process was assessed by the BBA, and the following requirements apply in order to satisfy the performance assessed in this Certificate.

9.1.2 Since insulating dry linings are not intended to resist rain penetration or rising damp, walls to be insulated with the products must already be rain resistant and show no signs of water ingress or rising damp.

9.1.3 When insulating solid walls, particularly older exposed walls, designers must consider the extent to which the wall and components in the wall can tolerate the lower temperatures and prolonged drying time resulting from the application of the insulating dry lining. Care must also be taken to assess the risks of condensation forming on thermal bridges that cannot be effectively insulated.

9.1.4 All services which penetrate the products, eg light switches and power outlets, must be kept to a minimum to limit damage to vapour checks. All perimeters of the board, around service penetrations, openings, junctions and around the perimeter of suspended timber floors must be sealed with a suitable sealant. The Certificate holder can advise on suitable materials, but such advice and products are outside the scope of this Certificate.

9.1.5 It is essential that proper care and attention is given to maintaining the integrity/continuity of the AVCL. The site must be surveyed, and provisions made for existing ventilation. There must be no gaps at the perimeter (such as floors or ceilings) or junctions (such as internal corners), or around openings or service penetrations. Existing gaps should be sealed before lining commences.

9.1.6 The detailed guidance given in the documents supporting the national Building Regulations for the provisions that are applicable when the products are installed in close proximity to certain flue pipes and/or heat-producing appliances must be followed.

9.1.7 As with any form of insulation, de-rating of electrical cables must be considered where the insulation restricts the air cooling of cables.

9.1.8 With installations that form a void of 20 mm or more (ie timber batten or metal liner stud system and drywall adhesive dabs), services can be incorporated behind the products, making the chasing of the wall unnecessary. Where the services have a greater depth than the void, the wall must be chased, rather than the insulation. Suitable isolation methods, such as a conduit or capping, must be used to ensure cables do not meet the insulation.

9.1.9 The installation of an insulating dry lining system requires careful detailing around doors and windows to achieve a satisfactory surface for finishing. In addition, every attempt must be made to minimise the risk of thermal bridging at reveals and where heavy separating walls are attached to the external wall. Thinner boards must be selected to suit site-specific door and window reveal conditions. All work must be designed to accommodate the thickness of the dry lining, particularly at reveals, heads and sills and in relation to ceiling height. Where the dimensions of fixtures are critical (eg bathrooms), these should be checked before installation.

9.1.10 Use of the products does not in itself promote infestation. The creation of voids within the structure may provide habitation for insects or vermin in areas already infested. All voids must be sealed, as any infestation may be difficult to eradicate. There is no food value in the materials used.

9.1.11 Calculations of thermal transmittance (U value) for a specific construction must be carried out in accordance with BS EN ISO 6946 : 2017 and BRE Report BR 443 : 2019.

9.1.12 Care must be taken in the overall design and construction of junctions with other elements and openings to minimise thermal bridges and air infiltration, and the detailed guidance given in the documents supporting the national Building Regulations must be followed.

9.1.13 The fixing of items, except lightweight objects, to the wall is outside the scope of this Certificate. Heavy objects (such as sinks and cupboards) must be adequately supported by the substrate wall, not the products.

### ***Masonry walls***

9.1.14 Walls must be designed and constructed in accordance with the relevant recommendations of:

- BS 5250 : 2021
- BS 8000-3 : 2020
- BS EN 351-1 : 2023
- BS EN 1996-1-1 : 2022 and its UK National Annex
- BS EN 1996-1-2 : 2024 and its UK National Annex
- BS EN 1996-2 : 2006 and its UK National Annex
- BS EN 1996-3 : 2023 and its UK National Annex

### ***Pitched roofs***

9.1.15 Pitched roofs must be designed and constructed in accordance with the relevant clauses of BS 5250 : 2021, BS 5534 : 2014 and BS 8000-8 : 2023 and incorporate normal precautions against moisture ingress.

9.1.16 In tiled or slated pitched roofs, the products are suitable for use beneath the rafters in conjunction with a BBA-approved breathable membrane and, when necessary, an AVCL.

9.1.17 New constructions subject to the national Building Regulations must be designed in accordance with the relevant recommendations of BS 5268-2 : 2002, and BS EN 1995-1-1 : 2004 and its UK National Annex.

### ***Interstitial condensation***

9.1.18 To limit the risk of interstitial condensation, walls and roofs must be designed and constructed in accordance with BS 5250 : 2021.

### ***Surface condensation***

9.1.19 In England and Wales, walls will adequately limit the risk of surface condensation when the thermal transmittance (U value) does not exceed  $0.7 \text{ W}\cdot\text{m}^{-2}\cdot\text{K}^{-1}$  at any point, and the junctions with other elements are designed in accordance with section 9.1.12 of this Certificate.

9.1.20 In England and Wales, roofs will adequately limit the risk of surface condensation when the thermal transmittance (U value) does not exceed  $0.35 \text{ W}\cdot\text{m}^{-2}\cdot\text{K}^{-1}$  at any point, and the junctions with walls are designed in accordance with section 9.1.12 of this Certificate.

9.1.21 For buildings in Scotland, wall and roof constructions will be acceptable where the thermal transmittance (U value) does not exceed  $1.2 \text{ W}\cdot\text{m}^{-2}\cdot\text{K}^{-1}$  at any point, and openings and junctions with other elements comply with BS 5250 : 2021, BRE Report BR 262 : 2002 and section 9.1.12 of this Certificate.

## 9.2 Installation

9.2.1 Installation instructions provided by the Certificate holder were assessed and judged to be appropriate and adequate.

9.2.2 Installation must be carried out in accordance with this Certificate, the Certificate holder's instructions and the relevant sections of BS 8000-8 : 2023. A summary of instructions and guidance is provided in Annex A.

9.2.3 A qualified plumber is required to make alterations to heating systems. A qualified electrician must be used to make good the electrical wirings and services.

9.2.4 A detailed survey of the property must be carried out before work starts, which must include:

- suitability of substrate
- detailing around windows and doors
- position and number of electrical sockets and switches
- wall fittings and fixtures — including coving and skirting
- areas where flexible sealants must be used
- ventilation plates.

9.2.5 If present, mould or fungal growth must be treated prior to the application of the products.

9.2.6 Before starting to fit the products, the position of all main service cable and pipe runs must be clearly marked on the walls to avoid damage. All plaster coving, skirting board and laminate floor angle bead must be removed.

9.2.7 Before fixing the products, sufficient time must be allowed for damp-proofing treatments, where applied, to dry out. Reference must be made to BS 6576 : 2005 for dry lining in conjunction with a chemical DPC application.

9.2.8 A detailed inspection of existing timbers for dry or wet rot and insect attack must also be carried out, eg for the timber floor joists. Existing metal studs or joists must be inspected for corrosion. Decayed timbers or corroded metal must be replaced.

9.2.9 All insulated dry lining installations require careful planning and setting out. Installation must start from an internal corner or a window or door reveal, and vertical chalk guidelines must be marked on the wall at 1200 mm centres to indicate the positioning of the boards.

9.2.10 Additional consideration must also be given for the fixing of such features as cupboards and radiators.

9.2.11 The boards can be cut using a fine-toothed saw. Appropriate Personal Protective Equipment (PPE) must be used when cutting the boards and cutting must be carried out in a ventilated space, outside or in an area with dust extraction.

## 9.3 Workmanship

Practicability of installation was assessed by the BBA on the basis of the Certificate holder's information. To achieve the performance described in this Certificate, installation of the products must be carried out by a competent general builder, or a contractor, experienced with these types of products.

#### 9.4 Maintenance and repair

Under conditions of normal use, maintenance is not required. However, if the products are damaged during use, they can be removed and replaced.

### **10 Manufacture**

10.1 The production processes for the products have been assessed, and provide assurance that the quality controls are satisfactory according to the following factors:

10.1.1 The manufacturer has provided documented information on the materials, processes, testing and control factors.

10.1.2 The quality control operated over batches of incoming materials has been assessed and deemed appropriate and adequate.

10.1.3 The quality control procedures and product testing to be undertaken have been assessed and deemed appropriate and adequate.

10.1.4 The process for management of non-conformities has been assessed and deemed appropriate and adequate.

10.1.5 An audit of each production location was undertaken, and it was confirmed that the production process was in accordance with the documented process, and that equipment has been properly tested and calibrated.

† 10.2 The BBA has undertaken to review the above measures on a regular basis through a surveillance process, to verify that the specifications and quality control operated by the manufacturer are being maintained.

### **11 Delivery and site handling**

11.1 The Certificate holder stated that the products are delivered to site in polythene-wrapped packs on pallets. Each pack of boards contains a label with the product and Certificate holder's names, board dimensions, year of manufacture, batch code and the BBA logo incorporating the number of this Certificate.

11.2 Delivery and site handling must be performed in accordance with the Certificate holder's instructions and this Certificate, including:

11.2.1 The pallets must be mechanically unloaded, and each board removed individually.

11.2.2 The products must be protected from prolonged exposure to sunlight, and stored dry, flat and raised above ground level. Where possible, packs should be stored inside. If stored outside, they must be under cover or protected with opaque polythene sheeting.

11.2.3 The products must not be exposed to open flame or other ignition sources, or to solvents or other chemicals.

Supporting information in this Annex is relevant to the products but has not formed part of the material assessed for the Certificate.

### Construction (Design and Management) Regulations 2015

### Construction (Design and Management) Regulations (Northern Ireland) 2016

Information in this Certificate may assist the client, designer (including Principal Designer) and contractor (including Principal Contractor) to address their obligations under these Regulations.

### CE marking

The Certificate holder has taken the responsibility of CE marking the products in accordance with harmonised European Standard EN 13950 : 2014.

### Management Systems Certification for production

The management system of the manufacturer has been assessed and registered as meeting the requirements of BS EN ISO 9001 : 2015, BS EN ISO 14001 : 2015 and BS ISO 45001 : 2018 by BRE (Certificates 718 QMS, 718 EMS and 718 HS respectively).

### Additional information on installation

A.1 The products can be installed mechanically or adhesively. XT/TL is installed by direct bonding to the wall using plaster adhesive dabs (XT/TL), while XT/TL-MF is installed by mechanical fixing either directly to the wall onto timber battens or metal furring systems, or to the underside of timber rafters or ceiling joists.

#### **Adhesive dab installation (with additional mechanical fixings)**

A.2 Adhesive dabs should be applied to the wall, ensuring a 50 mm continuous ribbon at the top and bottom, and around corners, openings and service penetrations. Dabs should be applied in accordance with BS 8000-8 : 2023.

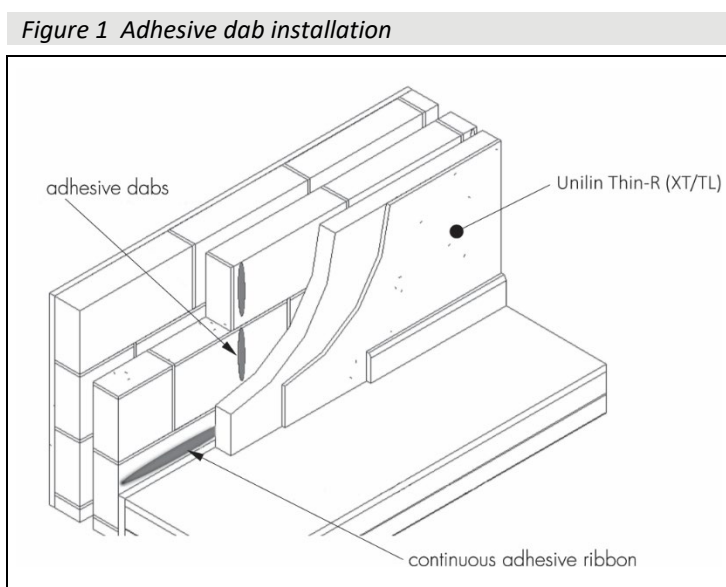

A.3 The board is placed onto the wall and positioned using wedges. Pressure is applied to level the board until it is firmly embedded into the adhesive.

A.4 A minimum of three thermally broken metal fixings must be provided for each board, applied after the adhesive has set, in accordance with BS 8000-8 : 2023 and the Certificate holder's instructions.

### **Mechanically fixed directly to the wall**

A.5 The board should be cut approximately 15 mm short of the floor to ceiling height and positioned with the bottom edge resting on packing strips. The boards are placed into position, and alignment checked with the chalk lines on the floor and ceiling.

A.6 Once positioned, the board should be lifted to the ceiling edge using a floor lifter and supported with additional packing at the base of the board. The board must be fixed to the wall using appropriate stainless steel mechanical fixings at 300 mm centres from the vertical and horizontal board edges, with a minimum of 12 fixings per board.

A.7 Other boards should be installed closely butted together using the same technique.

### **Adhesive dabs and batten installation**

A.8 Pre-treated timber battens are fixed horizontally at ceiling level and 20 mm above the finished floor level.

A.9 Where necessary, the insulation component should be cut back at the top and bottom of the board to accommodate the timber battens. The insulation should also be cut back at external corners to accommodate adjoining panels.

*Figure 2 Adhesive dab and batten installation*

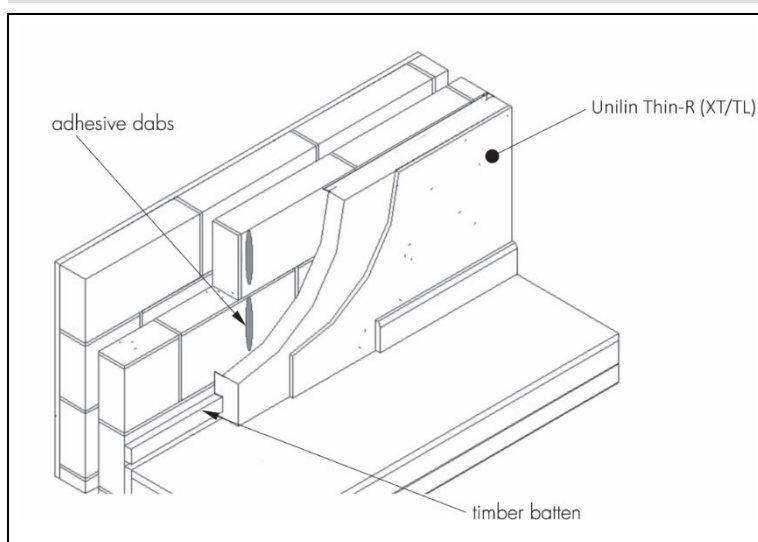

A.10 Adhesive dabs are applied to the back of the board, and continuous ribbons of adhesive are placed around any openings or service penetrations.

A.11 The board is placed onto the wall and positioned using wedges. Pressure is applied to level the board until it is firmly embedded into the adhesive.

A.12 The board is fixed to the top and bottom battens using screws placed at a minimum of 150 mm centres. Screws must be placed at least 12 mm from the edge of the board, and they should penetrate a minimum of 25 mm into the timber batten. A minimum of three nailable plugs should be used per sheet.

### **Mechanical — batten or metal furrings installation**

A.13 Pre-treated timber battens or metal furrings are fixed horizontally at ceiling level and 20 mm above the finished floor. Vertical timber or steel members should be fixed at a maximum of 600 mm centres and additional battens/metal furrings should be used to support all board edges. All openings should be trimmed with timber or metal furrings.

A.14 Care must be taken to ensure the battens/metal furrings are wide enough to offer a minimum of 20 mm support to all four edges of the plasterboard.

**Figure 3 Batten or metal furring installation**

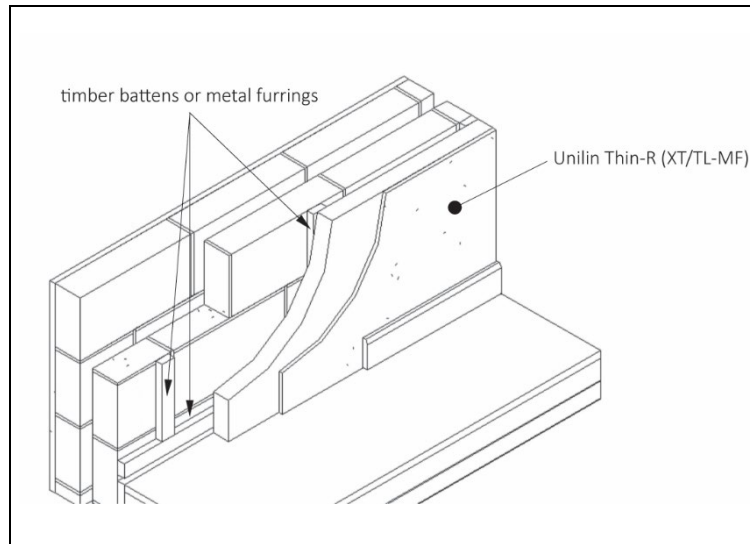

A.15 Where necessary, external corners of the insulation component of the board should be cut back to accommodate adjoining panels.

A.16 The board is placed onto the wall and positioned using wedges and is fixed to the battens using screws placed at a minimum of 150 mm centres. Screws must be placed at least 12 mm from the edge of the board, and they must penetrate a minimum of 25 mm into the timber batten.

#### **Ceiling installation**

A.17 The product may be used to line horizontal or sloped ceilings. All four edges of the liners should be supported by rafters, joists or battens by at least 19 mm. This may necessitate the addition of timber noggings.

**Figure 4 Ceiling installation**

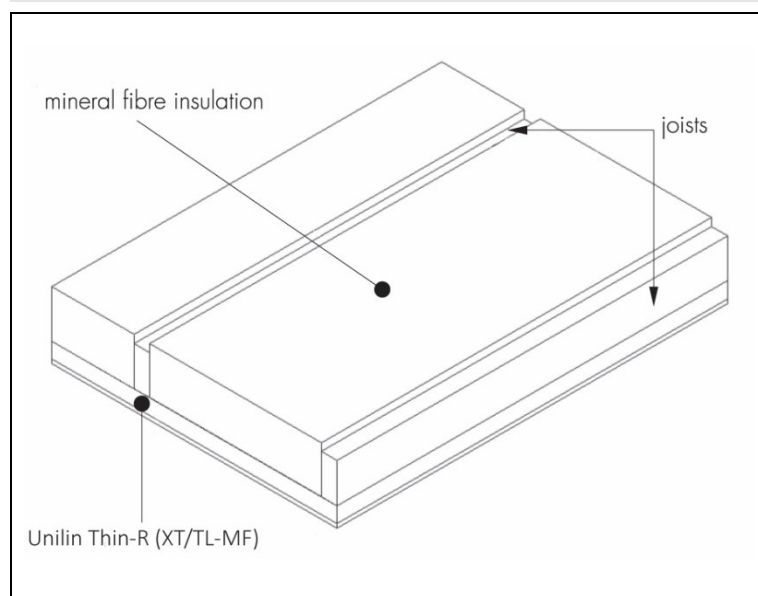

A.18 The board must be fixed using suitable large-headed clout nails, sherardised nails or dry lining screws.

A.19 The board should be fixed to all the rafters at a minimum of 250 mm centres. Fixings must be at least 12 mm from the edge of the thermal liner and must penetrate a minimum of 25 mm into the timber.

## **Finishing**

A.20 Jointing and finishing of the plasterboard lining are carried out in the appropriate manner in accordance with BS EN 13914-2 : 2016, applying plasterer's tape to all joints. A finishing skim coat of 2 mm of plaster should be applied to complete the installation.

A.21 Any gaps between the ceiling and the wall must be filled.

## Bibliography

- BRE Report BR 262 : 2002 *Thermal insulation: avoiding risks*
- BRE Report BR 443 : 2019 *Conventions for U-value calculations*
- BS 5250 : 2021 *Management of moisture in buildings — Code of practice*
- BS 5268-2 : 2002 *Structural use of timber — Code of practice for permissible stress design, materials and workmanship*
- BS 5534 : 2014 + A2 : 2018 *Code of practice for slating and tiling (including shingles)*
- BS 6576 : 2005 + A1 : 2012 *Code of practice for diagnosis of rising damp in walls of buildings and installation of chemical damp-proof courses*
- BS 8000-3 : 2020 *Workmanship on building sites — Code of practice for masonry*
- BS 8000-8 : 2023 *Workmanship on construction sites — Design and installation of dry lining systems — Code of practice*
- BS EN 351-1 : 2023 *Durability of wood and wood-based products — Preservative-treated solid wood*
- BS EN 826 : 2013 *Thermal insulating products for building applications — Determination of compression behaviour*
- BS EN 1604 : 2013 *Thermal insulating products for building applications — Determination of dimensional stability under specified temperature and humidity conditions*
- BS EN 1995-1-1 : 2004 + A2 : 2014 *Eurocode 5 — Design of timber structures — General — Common rules and rules for buildings*
- NA to BS EN 1995-1-1 : 2004 + A1 : 2008 UK National Annex to *Eurocode 5 : Design of timber structures — General — Common rules and rules for buildings*
- BS EN 1996-1-1 : 2022 *Eurocode 6 — Design of masonry structures — General rules for reinforced and unreinforced masonry structures*
- NA to BS EN 1996-1-1 : 2022 UK National Annex to *Eurocode 6 — Design of masonry structures — General rules for reinforced and unreinforced masonry structures*
- BS EN 1996-1-2 : 2024 *Eurocode 6 — Design of masonry structures — General rules — Structural fire design*
- NA to BS EN 1996-1-2 : 2024 UK National Annex to *Eurocode 6 — Design of masonry structures — General rules — Structural fire design*
- BS EN 1996-2 : 2006 *Eurocode 6 — Design of masonry structures — Design considerations, selection of materials and execution of masonry*
- NA to BS EN 1996-2 : 2006 UK National Annex to *Eurocode 6 — Design of masonry structures — Design considerations, selection of materials and execution of masonry*
- BS EN 1996-3 : 2023 *Eurocode 6 — Design of masonry structures — Simplified calculation methods for unreinforced masonry structures*
- NA to BS EN 1996-3 : 2023 UK National Annex to *Eurocode 6 — Design of masonry structures — Simplified calculation methods for unreinforced masonry structures*
- BS EN 12086 : 2013 *Thermal insulating products for building applications — Determination of water vapour transmission properties*
- BS EN 13165 : 2012 + A2 : 2016 *Thermal insulation products for buildings — Factory made rigid polyurethane foam (PUR) products — Specification*
- BS EN 13501-1 : 2018 *Fire classification of construction products and building elements — Classification using test data from reaction to fire tests*
- BS EN 13914-2 : 2016 *Design, preparation and application of external rendering and internal plastering — Internal plastering*
- BS EN 13950 : 2014 *Gypsum board thermal/acoustic insulation composite panels — Definitions, requirements and test methods*
- BS EN 13963 : 2014 *Jointing materials for gypsum boards — Definitions, requirements and test methods*
- BS EN 14496 : 2017 *Gypsum based adhesives for thermal/acoustic insulation composite panels and gypsum boards — Definitions, requirements and test methods*
- BS EN 15026 : 2023 *Hygrothermal performance of building components and building elements — Assessment of moisture transfer by numerical simulation*

BS EN 16012 : 2012 + A1 : 2015 *Thermal insulation for buildings — Reflective insulation products — Determination of the declared thermal performance*

BS EN ISO 6946 : 2017 *Building components and building elements — Thermal resistance and thermal transmittance — Calculation method*

BS EN ISO 9001 : 2015 *Quality management systems — Requirements*

BS EN ISO 10456 : 2007 *Building materials and products — Hygrothermal properties — Tabulated design values and procedures for determining declared and design thermal values*

BS EN ISO 14001 : 2015 *Environmental Management systems — Requirements with guidance for use*

BS ISO 45001 : 2018 *Occupational health and safety management systems — Requirements with guidance for use*

### Conditions

#### 1 This Certificate:

- relates only to the products that are named and described on the front page
- is issued only to the company, firm, organisation or person named on the front page – no other company, firm, organisation or person may hold or claim that this Certificate has been issued to them
- is valid only within the UK
- has to be read, considered and used as a whole document – it may be misleading and will be incomplete to be selective
- and any matter arising out of or in connection with it or its subject matter (including non-contractual disputes or claims) is governed by and construed in accordance with the law of England and Wales.
- the courts of England and Wales shall have exclusive jurisdiction to settle any matter arising out of or in connection with this Certificate or its subject matter (including non-contractual disputes or claims).

2 Publications, documents, specifications, legislation, regulations, standards and the like referenced in this Certificate are those that were current and/or deemed relevant by the BBA at the date of issue or reissue of this Certificate.

3 This Certificate will be displayed on the BBA website, and the Certificate Holder is entitled to use the Certificate and Certificate logo, provided that the product and its manufacture and/or fabrication, including all related and relevant parts and processes thereof:

- are maintained at or above the levels which have been assessed and found to be satisfactory by the BBA
- continue to be checked as and when deemed appropriate by the BBA under arrangements that it will determine
- are reviewed by the BBA as and when it considers appropriate.

4 The BBA has used due skill, care and diligence in preparing this Certificate, but no warranty is provided.

5 In issuing this Certificate the BBA is not responsible and is excluded from any liability to any company, firm, organisation or person, for any matters arising directly or indirectly from:

- the presence or absence of any patent, intellectual property or similar rights subsisting in the products or any other product
- the right of the Certificate holder to manufacture, supply, install, maintain or market the products
- actual installations of the products, including their nature, design, methods, performance, workmanship and maintenance
- any works and constructions in which the products are installed, including their nature, design, methods, performance, workmanship and maintenance
- any loss or damage, including personal injury, howsoever caused by the products, including their manufacture, supply, installation, use, maintenance and removal
- any claims by the manufacturer relating to UKCA marking and CE marking.

6 Any information relating to the manufacture, supply, installation, use, maintenance and removal of these products which is contained or referred to in this Certificate is the minimum required to be met when the products are manufactured, supplied, installed, used, maintained and removed. It does not purport in any way to restate the requirements of the Health and Safety at Work etc. Act 1974, or of any other statutory, common law or other duty which may exist at the date of issue or reissue of this Certificate; nor is conformity with such information to be taken as satisfying the requirements of the 1974 Act or of any statutory, common law or other duty of care.