

Unilin Insulation Ireland Ltd

Liscarton Ind Est
Kells Rd, Navan
Co Meath C15 NP79

Tel: 0371 222 1033

e-mail: info.ui@unilin.com

website: www.unilininsulation.co.uk



Agrément Certificate

23/6874

Product Sheet 5 Issue 1

UNILIN XTROLINER (XO)

UNILIN XTROLINER UNDERFLOOR INSULATION (XO/UF)

This Agrément Certificate Product Sheet⁽¹⁾ relates to Unilin XtroLiner Underfloor Insulation (XO/UF), comprising rigid polyisocyanurate (PIR) foam boards with a textured aluminium foil-facing on both sides, for use as insulation in ground-bearing or suspended concrete ground floors or between the joists of suspended timber ground-floors, in new and existing domestic buildings.

(1) Hereinafter referred to as 'Certificate'.

The assessment includes

Product factors:

- compliance with Building Regulations
- compliance with additional regulatory or non-regulatory information where applicable
- evaluation against technical specifications
- assessment criteria and technical investigations
- uses and design considerations

Process factors:

- compliance with Scheme requirements
- installation, delivery, handling and storage
- production and quality controls
- maintenance and repair

Ongoing contractual Scheme elements†:

- regular assessment of production
- formal 3-yearly review



KEY FACTORS ASSESSED

- Section 1. Mechanical resistance and stability
- Section 2. Safety in case of fire
- Section 3. Hygiene, health and the environment
- Section 4. Safety and accessibility in use
- Section 5. Protection against noise
- Section 6. Energy economy and heat retention
- Section 7. Sustainable use of natural resources
- Section 8. Durability

The BBA has awarded this Certificate to the company named above for the product described herein. This product has been assessed by the BBA as being fit for its intended use provided it is installed, used and maintained as set out in this Certificate.

On behalf of the British Board of Agrément

Date of issue: 7 June 2023

Hardy Giesler
Chief Executive Officer

This BBA Agrément Certificate is issued under the BBA's Inspection Body accreditation to ISO/IEC 17020. Sections marked with † are not issued under accreditation.

The BBA is a UKAS accredited Inspection Body (No. 4345), Certification Body (No. 0113) and Testing Laboratory (No. 0357).

Readers MUST check that this is the latest issue of this Agrément Certificate by either referring to the BBA website or contacting the BBA directly.

The Certificate should be read in full as it may be misleading to read clauses in isolation.

Any photographs are for illustrative purposes only, do not constitute advice and should not be relied upon.

British Board of Agrément

1st Floor Building 3
Croxley Park, Watford
Herts WD18 8YG

©2023

tel: 01923 665300
clientservices@bbacerts.co.uk
www.bbacerts.co.uk

SUMMARY OF ASSESSMENT AND COMPLIANCE

This section provides a summary of the assessment conclusions; readers should refer to the later sections of this Certificate for information about the assessments carried out.

Compliance with Regulations

Having assessed the key factors, the opinion of the BBA is that Unilin Xtroliner Underfloor Insulation (XO/UF), if installed, used and maintained in accordance with this Certificate, can satisfy or contribute to satisfying the relevant requirements of the following Building Regulations:



The Building Regulations 2010 (England and Wales) (as amended)

Requirement:	A1	Loading
Comment:		The product can contribute to satisfying this Requirement. See section 1 of this Certificate.
Requirement:	C2(c)	Resistance to moisture
Comment:		The product can contribute to satisfying this Requirement. See section 3 of this Certificate.
Requirement:	L1(a)(i)	Conservation of fuel and power
Comment:		The product can contribute to satisfying this Requirement. See section 6 of this Certificate.
Regulation:	7(1)	Materials and workmanship
Comment:		The product is acceptable. See sections 8 and 9 of this Certificate.
Regulation:	25B	Nearly zero-energy requirements for new buildings
Regulation:	26	CO₂ emission rates for new buildings
Regulation:	26A	Fabric energy efficiency rates for new dwellings (applicable to England only)
Regulation:	26A	Primary energy rates for new buildings (applicable to Wales only)
Regulation:	26B	Fabric performance values for new dwellings (applicable to Wales only)
Regulation:	26C	Target primary energy rates for new buildings (applicable to England only)
Regulation:	26C	Energy efficiency rating (applicable to Wales only)
Comment:		The product can contribute to satisfying these Regulations. See section 6 of this Certificate.



The Building (Scotland) Regulations 2004 (as amended)

Regulation:	8(1)	Fitness and durability of materials and workmanship
Comment:		The product is acceptable. See sections 8 and 9 of this Certificate.
Regulation:	9	Building standards applicable to construction
Standard:	1.1(b)	Structure
Comment:		The product can contribute to satisfying this Standard, with reference to clause 1.1.2 ⁽¹⁾ . See section 1 of this Certificate.
Standard:	3.15	Condensation
Comment:		The product can contribute to satisfying this Standard, with reference to clauses 3.15.1 ⁽¹⁾ , 3.15.4 ⁽¹⁾ and 3.15.5 ⁽¹⁾ . See section 3 of this Certificate.
Standard:	6.1(b)(c)	Energy demand and carbon dioxide emissions
Comment:	(d)	The product can contribute to satisfying this Standard with reference to clause 6.1.1 ⁽¹⁾ . See section 6 of this Certificate.

Standard: Comment:	6.2	Building insulation envelope The product can contribute to satisfying these Standards, with reference to clauses or parts of clauses, 6.2.1 ⁽¹⁾ , 6.2.3 ⁽¹⁾ , 6.2.6 ⁽¹⁾ , 6.2.7 ⁽¹⁾ , 6.2.8 ⁽¹⁾ , 6.2.9 ⁽¹⁾ , 6.2.10 ⁽¹⁾ , 6.2.11 ⁽¹⁾ and 6.2.12 ⁽¹⁾ . See section 6 of this Certificate.
Standard: Comment:	7.1(a)(b)	Statement of sustainability The product can contribute to satisfying the relevant requirements of Regulation 9, Standards 1 to 6, and therefore will contribute to a construction meeting at least a bronze level of sustainability as defined in this Standard. In addition, the product can contribute to a construction meeting a higher level of sustainability as defined in this Standard, with reference to clauses 7.1.2 ⁽¹⁾ , 7.1.4 ⁽¹⁾ , 7.1.6 ⁽¹⁾ and 7.1.7 ⁽¹⁾ . See section 6 of this Certificate.
Regulation: Comment:	12	Building standards applicable to conversions Comments made in relation to this product under Regulation 9, Standards 1 to 6, also apply to this Regulation, with reference to clause 0.12.1 ⁽¹⁾ and Schedule 6 ⁽¹⁾ .

(1) Technical Handbook (Domestic).



The Building Regulations (Northern Ireland) 2012 (as amended)

Regulation: Comment:	23(1)(a)(i) (iii)(b)(i)(ii)	Fitness of materials and workmanship The product is acceptable. See sections 8 and 9 of this Certificate.
Regulation: Comment:	29	Condensation The product can contribute to satisfying this Regulation. See section 3 of this Certificate.
Regulation: Comment:	30	Stability The product can contribute to satisfying this Regulation. See section 1 of this Certificate.
Regulation: Regulation: Regulation: Regulation: Comment:	39(a)(i) 40(2) 43(1)(2) 43B	Conservation measures Target carbon dioxide emission rate Renovation of thermal elements Nearly zero-energy requirements for new buildings The product can contribute to satisfying these Regulations. See section 6 of this Certificate.

Additional Information

NHBC Standards 2023

In the opinion of the BBA, Unilin XtroLiner Underfloor Insulation (XO/UF), if installed, used and maintained in accordance with this Certificate, can satisfy or contribute to satisfying the relevant requirements in relation to *NHBC Standards*, Chapters 5.1 *Substructure and ground bearing floors* and 5.2 *Suspended ground-floors*.

Fulfilment of Requirements

The BBA has judged Unilin XtroLiner Underfloor Insulation (XO/UF) to be satisfactory for use as described in this Certificate. The product has been assessed for use as insulation in ground-bearing or suspended concrete ground floors, or between the joists of suspended timber ground floors, in new or existing domestic buildings.

ASSESSMENT

Product description and intended use

The Certificate holder provided the following description for the product under assessment. Unilin XtroLiner Underfloor Insulation (XO/UF) comprises rigid polyisocyanurate (PIR) foam boards with textured foil-facing on both sides.

The product has the nominal characteristics given in Table 1.

Table 1 Nominal characteristics of Unilin XtroLiner Underfloor Insulation (XO/UF)

Characteristic	Value
Length	2400 mm
Width	1200 mm
Thickness	25, 30, 40, 50, 60, 75, 80, 90, 100, 110, 120, 130, 140 and 150 mm
Flatness (board length \leq 2.5 m; area $>$ 0.75 m ²)	Deviation \leq 10 mm
Edge profile	Square

The product is intended for use as floor insulation in new and existing domestic buildings:

- ground-supported concrete floors
- suspended concrete ground floors
- between the joists of suspended timber ground floors
- exposed or semi-exposed intermediate concrete or timber floors.

Ancillary items

The Certificate holder recommends the following ancillary items for use with the product, but these materials have not been assessed by the BBA and are outside the scope of this Certificate:

The overlay to the products should be:

- an air and vapour control layer (AVCL) where necessary (see section 3) and:
- a cement-based floor screed of minimum 65 mm⁽¹⁾ thickness, laid in accordance with the relevant clauses of BS 8204-1 : 2003 and/or BS 8204-2 : 2003, and BS 8000-9 : 2003 or
- wood-based floor [eg tongue-and-groove plywood to BS EN 636 : 2012, flooring grade particle board (Type P4 or P7) to BS EN 312 : 2010 or oriented strand board (type OSB/3 to OSB/4) to BS EN 300 : 2006], of a thickness to be determined by a suitably qualified and experienced individual, and installed in accordance with PD CEN/TR 12872 : 2014 and BS EN 12871 : 2013 or
- a concrete slab to BS EN 1992-1-1 : 2004.

(1) The NHBC only accept ground-supported floor slabs with at least 100 mm thick concrete including a monolithic screed.

Product assessment – key factors

The product was assessed for the following key factors, and the outcome of the assessments is shown below. Conclusions relating to the Building Regulations apply to the whole of the UK unless otherwise stated.

1 Mechanical resistance and stability

Data were assessed for the following characteristics.

1.1 Floor loading

1.1.1 The product was tested for compressive strength and the results are given in Table 2.

Table 2 Compressive strength

Product assessed	Assessment method	Requirement	Result
XtroLiner Underfloor Insulation (XO/UF)	BS EN 826 : 1996	Declared minimum compressive strength of the product at 10% deformation	150 kPa

1.1.2 On the basis of data assessed, the product is suitable for the occupancies defined in this Certificate when covered with a suitable floor overlay, and is capable of resisting a uniformly distributed load of $1.5 \text{ kN}\cdot\text{m}^{-2}$ or a concentrated load of 2 kN for category A1 and A2 (domestic) situations as defined in Table NA.2, in UK National Annex to BS EN 1991-1-1 : 2002. Further assessment by a suitably competent and experienced individual is necessary in the case of duty walkways and floors subject to physical activities.

1.1.3 The performance of a specific floor construction will depend on the insulation properties and type of floor overlay used (including thickness and strength). When the product is used under a concrete slab, resistance to concentrated and distributed loads is a function of the slab specification. Further guidance on the suitability of floor overlays can be found in BS EN 13810-1 : 2002, DD CEN/TS 13810-2 : 2003, BS 8204-1 : 2003 and BS EN 312 : 2010, and from the flooring manufacturer, although the latter is outside of the scope of this Certificate.

2 Safety in case of fire

Data were assessed for the following characteristics.

2.1 Reaction to fire

2.1.1 The product was tested for reaction to fire and the classification is given in Table 3.

Table 3 Reaction to fire classification

Product assessed	Assessment method	Requirement	Result
Xtroliner PIR board bonded on each side to aluminium foil facers	BS EN 13501-1 : 2018	Reaction to fire classification	C-s2, d0

2.1.2 Details of the classification can be found in test report DO-19-1319\A-R1-AMDT1 (Issue no 1, 21/10/2019), issued by CREPIM, available from the Certificate holder. This classification is valid for thicknesses of 25 to 160 mm.

2.1.3 The designation, classification and/or permissible areas of other specifications should be confirmed by reference to the requirements of the documents supporting the national Building Regulations.

2.1.4 Where an intermediate floor incorporating the product is required to achieve a period of fire resistance, its performance should be confirmed by a suitably qualified and experienced individual or by a test from a suitably accredited laboratory.

3 Hygiene, health and the environment

Data were assessed for the following characteristics.

3.1 Water vapour permeability

3.1.1 For the purposes of assessing the risk of interstitial condensation, the water vapour resistance/resistivity values may be taken as stated in Table 4.

Table 4 Water vapour resistance/resistivity

Material	Assessment method	Requirement	Result
PIR insulation	BS EN ISO 10456 : 2007	Declared value	$300 \text{ MN}\cdot\text{s}\cdot\text{g}^{-1}\cdot\text{m}^{-1}$
Foil facer	BS 5250 : 2021		$1000 \text{ MN}\cdot\text{s}\cdot\text{g}^{-1}$

3.2 Condensation

3.2.1 The BBA has assessed the product for the risk of interstitial condensation, and the following factors must be implemented.

3.2.1.1 When the product is used on a ground-bearing floor or a suspended concrete floor, an AVCL must be installed on the warm side of the insulation to inhibit the risk of interstitial condensation, unless a risk assessment shows this is not necessary.

3.2.1.2 Voids below suspended timber ground floors must be ventilated. Ventilation may be achieved by installing vents not less than $1500 \text{ mm}^2 \cdot \text{m}^{-1}$ run of external wall or $500 \text{ mm}^2 \cdot \text{m}^{-2}$ of floor area, whichever is the greater. Ventilation openings must be arranged to prevent the ingress of rain, snow, birds and small mammals and the risk of subsequent blockage by other building operations.

4 Safety and accessibility in use

Not applicable.

5 Protection against noise

Not applicable.

6 Energy economy and heat retention

Data were assessed for the following characteristics.

6.1 Thermal conductivity

6.1.1 The products were tested for thermal conductivity and emissivity and the results are given in Table 5.

Table 5 Thermal conductivity and emissivity

Material	Assessment method	Requirement	Result
PIR insulation	Thermal conductivity to BS EN 13165 : 2012 + A2 : 2016	Declared value (λ_D)	$0.021 \text{ W} \cdot \text{m}^{-1} \cdot \text{K}^{-1}$
Foil facer (unprinted)	Aged emissivity to BS EN 15976 : 2011	Declared value	0.03

6.2 Thermal performance

6.2.1 The U value of a completed floor will depend on the insulation thickness, the perimeter/area ratio, and the floor type. Example U-values are given in Table 6.

Table 6 Example U values – ground-floor construction

Floor Type	Target U value (W·m ⁻² ·K ⁻¹)	Unilin XtroLiner Underfloor Insulation (XO/UF) Insulation thickness (mm)				
		P/A ratio				
		0.2	0.4	0.6	0.8	1.0
Ground-bearing concrete floor ⁽¹⁾⁽⁴⁾	0.11	120	150	155 ⁽⁵⁾	160 ⁽⁵⁾	160 ⁽⁵⁾
	0.12	100	130	140	150	150
	0.13	90	120	130	130	140
	0.15	75	100	110	110	120
	0.18	50	75	90	90	100
	0.22	30	60	75	75	75
	0.25	25	50	60	60	60
Suspended concrete ground-floor ⁽²⁾⁽⁴⁾	0.11	130	150	155 ⁽⁵⁾	160 ⁽⁵⁾	160 ⁽⁵⁾
	0.12	120	140	140	150	150
	0.13	110	120	130	130	140
	0.15	90	100	110	110	120
	0.18	60	80	90	90	100
	0.22	40	60	75	75	75
	0.25	30	50	60	60	60
Suspended timber ground-floor ⁽³⁾	0.11	195 ⁽⁵⁾	225 ⁽⁵⁾	240 ⁽⁵⁾	240 ⁽⁵⁾	250 ⁽⁵⁾
	0.12	175 ⁽⁵⁾	205 ⁽⁵⁾	215 ⁽⁵⁾	220 ⁽⁵⁾	220 ⁽⁵⁾
	0.13	155 ⁽⁵⁾	185 ⁽⁵⁾	195 ⁽⁵⁾	200 ⁽⁵⁾	205 ⁽⁵⁾
	0.15	130	150	160 ⁽⁵⁾	170 ⁽⁵⁾	170 ⁽⁵⁾
	0.18	90	120	130	140	140
	0.22	60	90	100	100	110
	0.25	40	75	80	90	90

(1) Ground-bearing concrete floor construction (Unilin XtroLiner Underfloor Insulation (XO/UF) on top of slab, under screed finish) 65 mm concrete screed ($\lambda = 1.15 \text{ W}\cdot\text{m}^{-1}\cdot\text{K}^{-1}$), polyethylene separating layer, Unilin XtroLiner Underfloor Insulation (XO/UF), damp-proof membrane (DPM), 100 mm concrete oversite, 150 mm sand-blinded hardcore, ground ($\lambda = 1.5 \text{ W}\cdot\text{m}^{-1}\cdot\text{K}^{-1}$).

(2) Suspended concrete ground-floor construction (Unilin XtroLiner Underfloor Insulation (XO/UF) on top of beam and block, below screed finish) – 65 mm concrete screed $\lambda = 1.15 \text{ W}\cdot\text{m}^{-1}\cdot\text{K}^{-1}$, polyethylene separating layer, Unilin XtroLiner Underfloor Insulation (XO/UF), beam and block floor (12%) Beam ($\lambda = 2.00 \text{ W}\cdot\text{m}^{-1}\cdot\text{K}^{-1}$), dense block infill ($\lambda = 1.13 \text{ W}\cdot\text{m}^{-1}\cdot\text{K}^{-1}$), ventilated void.

(3) Suspended timber ground-floor construction (Unilin XtroLiner Underfloor Insulation (XO/UF) between floor joists) – floor deck based on 22 mm chipboard ($\lambda = 0.13 \text{ W}\cdot\text{m}^{-1}\cdot\text{K}^{-1}$), Unilin XtroLiner Underfloor Insulation (XO/UF) (89%) between 47 mm wide joists at 400 mm centres. The depth of the joists = 100 to 200 mm depending on the depth of insulation between timber ($\lambda = 0.13 \text{ W}\cdot\text{m}^{-1}\cdot\text{K}^{-1}$) floor joists (11%) based on BR 443 : 2019 (38 mm wide nogging every 3 metres).

(4) 25 mm edge insulation of Unilin XtroLiner Underfloor Insulation (XO/UF), 65 mm deep.

(5) Thickness created by using 2 boards.

6.2.2 The product can contribute towards a floor construction satisfying the national Building Regulations in respect of energy economy and heat retention.

7 Sustainable use of natural resources

Not applicable.

8 Durability

8.1 The potential mechanisms for degradation and the known performance characteristics of the materials in this product were assessed.

8.2 Data were assessed for the characteristics shown in Table 7:

Table 7 Dimensional stability, deformation and compressive creep

Product assessed	Assessment method	Requirement	Result
XtroLiner Underfloor Insulation (XO/UF)	Dimensional stability to BS EN 1604 : 2013 (70°C and 90-100% RH for 48 hours)	Declared value	Length and width ≤ 1 % change Thickness ≤ 4 % change
XtroLiner Underfloor Insulation (XO/UF)	Dimensional stability to BS EN 1604 : 2013 (-20°C for 48 hours)	Declared value	Length and width ≤ 0.5 % change Thickness ≤ 2 % change
XtroLiner Underfloor Insulation (XO/UF) at 25 and 50 mm thicknesses	Deformation to EN 1605 : 1999 + A1 : 2006 (Condition 1)	Value achieved	≤ 5 % deformation
XtroLiner Underfloor Insulation (XO/UF) At 25, 50, 80 and 140 mm thicknesses	Deformation to EN 1605 : 1999 + A1 : 2006 (Condition 2)	Value achieved	≤ 5 % deformation
XtroLiner Underfloor Insulation (XO/UF) at 25 and 50 mm thicknesses	Deformation to EN 1605 : 1999 + A1 : 2006 (Condition 3)	Value achieved	≤ 5 % deformation
XtroLiner Underfloor Insulation (XO/UF) at 25, 50, 80 and 120 mm thicknesses	Compressive creep to EN 1606 : 1999 + A1 : 2006 (40 kPa at 23°C and 50% RH)	Extrapolated long term deformation after 10 years value achieved	< 7 % deformation

8.3 Service life

8.3.1 Under normal service conditions, the product will have a life equivalent to the building in which it is incorporated, provided it is designed, installed and maintained in accordance with this Certificate and the Certificate holder's instructions.

Information provided by the Certificate holder was assessed for the following factors:

9 Design, installation, workmanship and maintenance

9.1 Design

9.1.1 The design process was assessed by the BBA, and the following requirements apply in order to satisfy the performance assessed in this Certificate.

9.1.2 The product can be used on suitably designed beam-and-block floors incorporating Type R2 semi-resisting or resisting blocks to BS EN 15037-2 : 2009 and self-bearing beams to BS EN 15037-1 : 2008.

9.1.3 Ground-bearing floors must only be used where the depth of compacted fill is less than 600 mm and is defined as non-shrinkable. Shrinkable fills are defined as material containing more than 35% fine particles (silt and clay) with a plasticity index of 10% or greater (shrinkable fills are susceptible to clay heave).

9.1.4 Ground-bearing concrete and suspended concrete ground-floors incorporating the product must include a suitable DPM, laid beneath the insulation, in accordance with the relevant sections of CP 102 : 1973, BS 8102 : 2009 and BS 8215 : 1991 (see section A.5 of this Certificate).

9.1.5 Suspended concrete or timber ground-floors incorporating the insulation boards must include suitable ventilation of the sub-floor void (minimum 150 mm void between the underside of the floor and the ground surface) or a DPM. For suspended floors in locations where clay heave is anticipated, an additional void of up to 150 mm may be required to accommodate the possible expansion of the ground below the floor. In such cases where the risk of clay heave has been confirmed by geotechnical investigations by a suitably competent and experienced individual, a total void of up to 300 mm may be required.

9.1.6 Where a concrete screed or slab finish is to be laid directly over the product, a polyethylene separating layer/AVCL must be installed between the insulation and the concrete to prevent chemical attack and seepage between the boards (see section A.6). Any gaps between insulation boards or around service openings, visible prior to installing the concrete, must be filled with expanding foam or strips of insulation.

9.1.7 Internal walls must not be built on the insulation.

9.1.8 Care must be taken in the overall design and construction of junctions with other elements and openings to minimise thermal bridges and air infiltration and the detailed guidance that can be found in the documents supporting the national Building Regulations must be followed.

Interstitial condensation

9.1.9 Floors will adequately limit the risk of interstitial condensation when they are designed and constructed in accordance with BS 5250 : 2021.

9.1.10 When the product is used above the DPM on a ground-bearing or suspended floor, an AVCL is installed on the warm side of the insulation to limit the risk of interstitial condensation, unless a risk assessment shows this is not necessary.

9.1.11 For suspended timber ground floors, it is not necessary to introduce an AVCL as long as adequate sub-floor cross ventilation is provided.

Surface condensation

9.1.12 In England and Wales, floors will adequately limit the risk of surface condensation when the thermal transmittance (U value) does not exceed $0.7 \text{ W}\cdot\text{m}^{-2}\cdot\text{K}^{-1}$ at any point, and the junctions with walls are designed in accordance with section 6.

9.1.13 Floors will adequately limit the risk of surface condensation when the thermal transmittance (U value) does not exceed $1.2 \text{ W}\cdot\text{m}^{-2}\cdot\text{K}^{-1}$ at any point and the floor is designed and constructed in accordance with the relevant parts of BS 5250 : 2021.

9.1.14 Further guidance may be obtained from BRE Report BR 262 : 2002 and section 6 of this Certificate.

9.2 Installation

9.2.1 Installation instructions provided by the Certificate holder were assessed and judged to be appropriate and adequate.

9.2.2 Installation must be carried out in accordance with this Certificate and the Certificate holder's instructions. A summary of instructions and guidance are provided in Annex A of this Certificate.

Incorporation of services

9.2.3 De-rating of electrical cables must be considered where the insulation restricts air cooling of cables; the product must not be used in direct contact with electrical heating cables or hot water pipes. Where underfloor heating systems are to be used, the advice of the Certificate holder should be sought, but such advice is outside of the scope of this Certificate.

9.2.4 Where possible, electrical conduits, gas and water pipes or other services must be contained within ducts or channels within the concrete slab of ground bearing floors. Where this is not possible, the services may be accommodated within the insulation, provided they are securely fixed to the concrete slab. Electrical cables that are likely to come into contact with the insulation must be protected by a suitable conduit or PVC-U trunking. With hot pipes, the insulation must be cut back to maintain an air space.

9.2.5 Where water pipes are installed below the insulation, they must be pre-lagged with close-fitting pipe insulation.

9.2.6 Where the product is installed on a floor of a suspended beam-and-block design, all services must be installed in accordance with a BBA Certificate for that floor and/or with the relevant codes of practice.

9.2.7 To provide support for a particle board cover on overlay board floors where access to the services is desirable, a duct may be formed by mechanically fixing to the floor, timber bearers of the same thickness as the insulation. The duct must be as narrow as possible and not exceed 400 mm in width or the maximum particle board spans given in DD CEN/TR 12872 : 2014 without intermediate support. Services must be suitably fixed to the floor base and not to the insulation boards (see section 9.1.8 of this Certificate regarding limiting heat loss).

9.2.8 On suspended timber ground floors, all the services must be incorporated beneath the existing floor, if possible.

9.3 Workmanship

9.3.1 Practicability of installation was assessed by the BBA on the basis of the Certificate holder's information. To achieve the performance described in this Certificate, installation of the product must be carried out by a competent general builder, or a contractor, experienced with this type of product.

9.4 Maintenance and repair

9.4.1 As the product is confined within the floor by the overlay and has suitable durability, maintenance is not required.

10 Manufacture

10.1 The production processes for the product have been assessed, and provide assurance that the quality controls are satisfactory according to the following factors:

10.1.1 The manufacturer has provided documented information on the materials, processes, testing and control factors.

10.1.2 The quality control operated over batches of incoming materials has been assessed and deemed appropriate and adequate.

10.1.3 The quality control procedures and product testing to be undertaken have been assessed and deemed appropriate and adequate.

10.1.4 The process for management of non-conformities has been assessed and deemed appropriate and adequate.

10.1.5 An audit of each production location was undertaken, and it was confirmed that the production process was in accordance with the documented process, and that equipment has been properly tested and calibrated.

† 10.1.6 The BBA has undertaken to review the above measures on a regular basis through a surveillance process, to verify that the specifications and quality control operated by the manufacturer are being maintained.

11 Delivery and site handling

11.1 The Certificate holder stated that the product is delivered to site shrink-wrapped in polythene-wrapped packs containing a label with the product description and characteristics, the manufacturer's name and the BBA logo incorporating the number of this Certificate.

11.2 Delivery and site handling must be performed in accordance with the Certificate holder's instructions and this Certificate, including:

11.2.1 The product must be stored such that it is raised off the ground, inside or under cover on a flat, dry, level surface in a well-ventilated area. The product must be protected from rain, snow, and prolonged exposure to sunlight. Boards that have been allowed to get wet or damaged must not be used. Nothing must be stored on top of the boards.

11.2.2 The products must not be exposed to open flame or other ignition sources, or to solvents or other chemicals.

ANNEX A – SUPPLEMENTARY INFORMATION †

Supporting information in this Annex is relevant to the product but has not formed part of the material assessed for the Certificate.

Construction (Design and Management) Regulations 2015

Construction (Design and Management) Regulations (Northern Ireland) 2016

Information in this Certificate may assist the client, designer (including Principal Designer) and contractor (including Principal Contractor) to address their obligations under these Regulations.

CE marking

The Certificate holder has taken the responsibility of CE marking the product, in accordance with harmonised European Standard EN 13165 : 2012.

Management Systems Certification for production

The management system of the manufacturer has been assessed and registered as meeting the requirements of BS EN ISO 9001 : 2015, BS EN ISO 14001 : 2015 and OHSAS 18001: 2007 by BRE (Certificates 1597QMS, 1597-EMS and 718-HS respectively).

Additional information on installation

A.1 Typical methods of installation are shown in Figures 1 to 6. Reference should also be made to BRE Report BR 262 : 2002.

Figure 1 Ground-bearing concrete floor – screed overlay

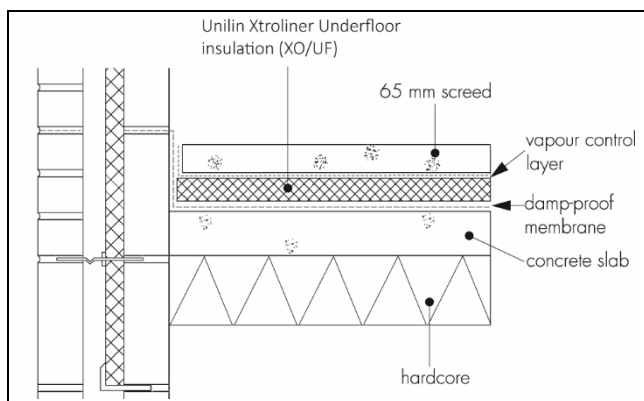

Figure 2 Suspended concrete ground floor – screed overlay

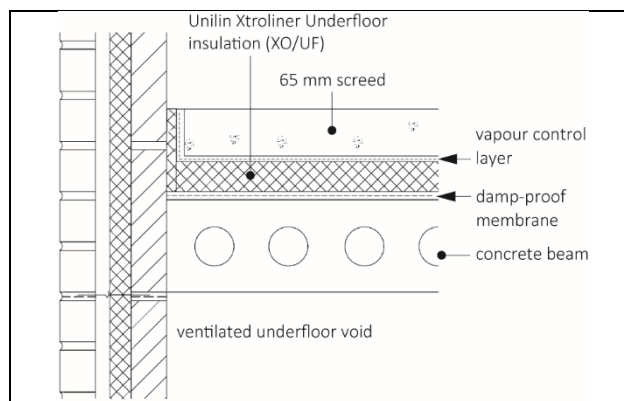

Figure 3 Ground-bearing concrete – slab overlay

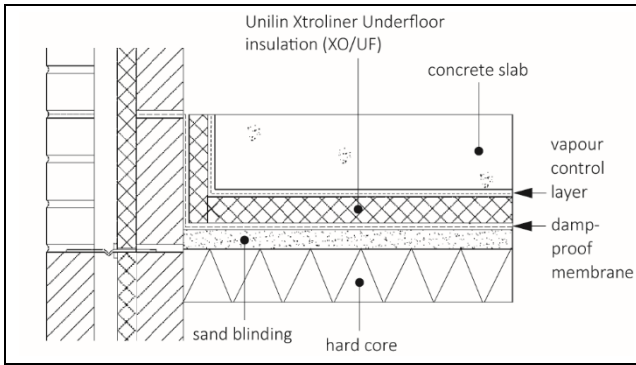

Figure 4 Ground-bearing concrete floor – board overlay

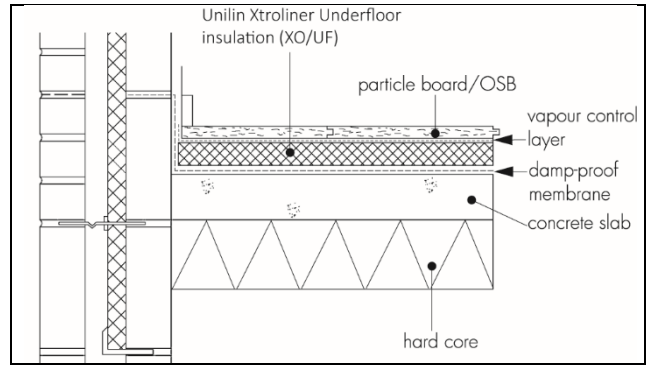

Figure 5 Suspended concrete ground floor – board overlay

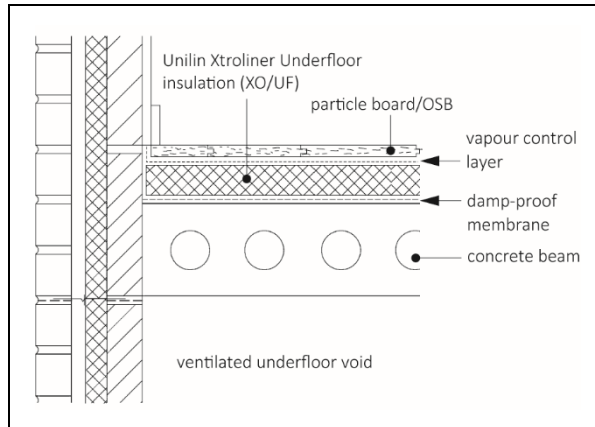
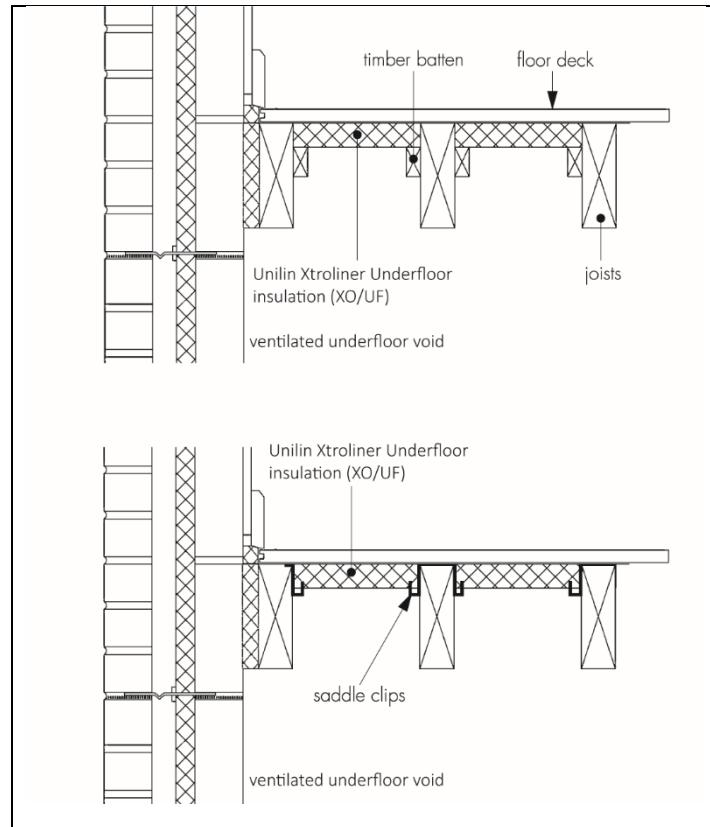

Figure 6 Suspended timber ground floors



A.2 In ground-bearing concrete floors, the concrete floor slab over which the boards are to be laid should be left for as long as possible to maximise drying out and dissipation of constructional moisture, in accordance with BS 8203 : 2017, Section 3.1.2.

A.3 The concrete floor surface should be smooth, level, and flat to within 5 mm when measured with a two-metre straight-edge. Irregularities greater than this must be removed. Minor irregularities (up to 10 mm deep) may be levelled with mortar or thin screed.

A.4 Where the insulation is used over ground-bearing concrete floor slabs, a suitable DPM in accordance with CP 102 : 1973 should be laid to resist moisture from the ground. If a liquid-type DPM is applied to the slabs, it should be of a type compatible with the product and be allowed to dry out fully before laying the insulation.

A.5 Where the insulation is used on hardcore bases beneath ground-bearing concrete slabs, the hardcore must be compacted and blinded with a thin layer of sand before application of the DPM, followed by the insulation boards.

A.6 An AVCL is installed on the warm side of the insulation to inhibit the risk of interstitial condensation if necessary (see section 3). Where a concrete screed or slab finish is to be laid directly over the product, a polyethylene separating layer/AVCL must be installed between the insulation and the concrete to prevent chemical attack and seepage between the boards.

A.7 Where a screed or concrete slab is laid over the insulation, vertical upstands of insulation should be provided and be of sufficient depth to fully separate the screed or slab from the wall. If used, a suitable cavity wall insulation material should be extended below the DPC level to provide edge insulation to the floor.

A.8 To limit the risk of condensation and other sources of dampness, the insulation and overlays should only be laid after the construction is made substantially weathertight, e.g., after glazing. During construction, the insulation and overlay must be protected from damage by traffic and moisture sources such as water spillage and plaster droppings.

Procedure

A.9 The product is cut to size (using a sharp knife or fine-toothed saw), as necessary, and laid with closely butted, staggered cross-joints, ensuring all spaces are completely filled.

A.10 The laying pattern should ensure that all cut edges are at the perimeter of the floor or some other feature, e.g., mat wells, thresholds or access ducts. Spreader boards should be used to protect the insulation.

Timber-based board overlay

A.11 Before laying the plywood, particle board or OSB overlay, preservative-treated timber battens, in accordance with BS 8417 : 2011, are positioned at doorways and access panels. Adequate time should be allowed for preservatives to be fixed, and the solvents from solvent-based preservatives to evaporate.

A.12 Where the insulation is laid above a DPM, a polyethylene AVCL of at least 0.125 mm (500 gauge) thickness is laid between the insulation and the timber board overlay. The AVCL should have 150 mm overlaps, taped at the joints and turned up 100 mm at the walls.

A.13 Timber based overlay boards as specified in section 9 are laid with staggered cross-joints, in accordance with PD CEN/TS 12872 : 2007 and BS EN 12871 : 2013.

A.14 An expansion gap between the overlay board and the perimeter walls should be provided at the rate of 2 mm per metre run or a minimum of 10 mm, whichever is the greater.

A.15 Where there are long, uninterrupted lengths of floor (eg, corridors), proprietary expansion joints should be installed at intervals, on the basis of a 2 mm gap per metre run of overlay board.

A.16 Before the overlay boards are interlocked, a water-resistant PVA adhesive is applied to the joints.

A.17 Once the overlay board is laid, temporary wedges are inserted between the walls and the floor to maintain tight joints until the adhesive has set.

A.18 When the wedges are removed and before the skirting boards are fixed, a suitable compressible filler, eg foamed polyethylene, should be fitted around the perimeter of the floor between the overlay board and the walls.

A.19 Where there is a likelihood of regular water spillage (eg, in kitchens, bathrooms, shower and utility rooms), additional overlay board protection should be considered, eg, by a continuous flexible vinyl sheet flooring, with welded joints, turned up at abutments and cove skirting.

Cement-based screed overlay

A.20 Perimeter edge pieces are cut and placed around the edges and taped at joints. A polyethylene AVCL, at least 0.125 mm thick (500 gauge), is laid over the insulation. The AVCL should have 150 mm overlaps, taped at the joints and turned up 100 mm at the walls. A properly compacted screed of minimum thickness 65 mm is then laid over. The relevant clauses of BS 8204-1 : 2003 should be followed.

Concrete slab overlay (ground-bearing only)

A.21 Perimeter edge pieces are cut and placed around the edges and taped at the joints. A polyethylene AVCL, minimum 0.125 mm thick (500 gauge), is laid over the insulation. The AVCL should have 150 mm overlaps, taped at the joints and turned up 100 mm at the walls. The concrete slab is laid to the required thickness in accordance with BS 8000-9 : 2003 and BS 8204-1 : 2003.

Suspended timber floor

A.22 Insulation boards can be supported between timber joists using either saddle clips or timber beads. Where timber beads are used, a void may be incorporated above the insulation to accommodate services, if required.

A.23 Saddle clips are placed at intervals not exceeding one metre along the timber floor joists. Where the product is to be installed on only one side of the joist, twin clips can be cut into single clips and nailed into place with galvanized nails.

A.24 If saddle clips are not used, the product may be retained using preservative-treated timber battens. The battens should be wide enough to retain the product in place and secured with corrosion-protected nails at a depth that will accommodate the thickness of the product.

A.25 The product should be cut to fit tightly between joists and pushed down onto the spikes of the saddle clips, or onto the beads. Small gaps should be insulated with cut strips of the product.

Bibliography

- BRE Report BR 262 : 2002 *Thermal insulation: avoiding risks*
- BRE Report BR 443 : 2006 *Conventions for U-value calculations*
- BS 5250 : 2021 *Management of moisture in buildings. Code of practice*
- BS 8000-9 : 2003 *Workmanship on building sites — Cementitious levelling screeds and wearing screeds — Code of practice*
- BS 8203 : 2017 *Code of practice for installation of resilient floor coverings*
- BS 8204-1 : 2003 + A1 : 2009 *Screeds, bases and in-situ floorings — Concrete bases and cement sand levelling screeds to receive floorings — Code of practice*
- BS 8204-2 : 2003 + A2 : 2011 *Screeds, bases and in-situ floorings — Concrete wearing surfaces — Code of practice*
- BS 8215 : 1991 *Code of practice for design and installation of damp-proof courses in masonry construction*
- BS 8417 : 2011 + A1 : 2014 *Preservation of wood — Code of practice*
- BS EN 300 : 2006 *Oriented Strand Boards (OSB) — Definitions, classification and specifications*
- BS EN 312 : 2010 *Particleboards — Specifications*
- BS EN 636 : 2012 + A1 : 2015 *Plywood — Specifications*
- BS EN 826 : 1996 *Thermal Insulating Products for Building Applications — Determination of Compression Behaviour*
- BS EN 1991-1-1 : 2002 *Eurocode 1 : Actions on structures — General actions — Densities, self-weight, imposed loads for buildings*
- NA to BS EN 1991-1-1 : 2002 *UK National Annex to Eurocode 1 : Actions on structures — General actions— Densities, self-weight, imposed loads for buildings*
- BS EN 1992-1-1 : 2004 + A1 : 2014 *Eurocode 2 : Design of concrete structures — General rules and rules for buildings*
- NA + A2 : 2014 TO BS EN 1992-1-1 : 2004 + A1 : 2014 *UK National Annex to Eurocode 2 — Design of concrete structures — General rules and rules for buildings*
- BS EN 12871 : 2013 *Wood-based panels — Determination of performance characteristics for load bearing panels for use in floors, roofs and walls*
- BS EN 13165 : 2012 + A2 : 2016 *Thermal insulation products for buildings — Factory made rigid polyurethane foam (PU) products — Specification*
- BS EN 13501-1 : 2007 + A1 : 2009 *Fire classification of construction products and building elements — Classification using test data from reaction to fire tests*
- BS EN 13810-1 : 2002 *Wood-based panels — Floating floors — Performance specifications and requirements*
- BS EN 15037-1 : 2008 *Precast concrete products — Beam-and-block floor systems — Beams*
- BS EN 15037-2 : 2009 + A1 : 2011 *Precast concrete products — Beam-and-block floor systems — Concrete blocks*
- BS EN 15976 : 2011 *Flexible sheets for waterproofing — Determination of emissivity*
- BS EN ISO 6946 : 2017 *Building components and building elements — Thermal resistance and thermal transmittance — Calculation method*
- BS EN ISO 9001 : 2015 *Quality management systems — Requirements*
- BS EN ISO 13370 : 2017 *Thermal Performance of buildings — Heat transfer via the ground — calculation methods*
- BS EN ISO 14001 : 2015 *Environmental management systems — Requirements with guidance for use*
- CP 102 : 1973 *Code of practice for protection of buildings against water from the ground*
- DD CEN/TS 13810-2 : 2003 *Wood-based panels — Floating floors — Test methods*
- PD CEN/TS 12872 : 2007 *Wood-based panels — Guidance on the use of load-bearing boards in floors, walls and roofs*

Conditions of Certificate

Conditions

1 This Certificate:

- relates only to the product that is named and described on the front page
- is issued only to the company, firm, organisation or person named on the front page – no other company, firm, organisation or person may hold or claim that this Certificate has been issued to them
- is valid only within the UK
- has to be read, considered and used as a whole document – it may be misleading and will be incomplete to be selective
- is copyright of the BBA
- is subject to English Law.

2 Publications, documents, specifications, legislation, regulations, standards and the like referenced in this Certificate are those that were current and/or deemed relevant by the BBA at the date of issue or reissue of this Certificate.

3 This Certificate will be displayed on the BBA website, and the Certificate Holder is entitled to use the Certificate and Certificate logo, provided that the product and its manufacture and/or fabrication, including all related and relevant parts and processes thereof:

- are maintained at or above the levels which have been assessed and found to be satisfactory by the BBA
- continue to be checked as and when deemed appropriate by the BBA under arrangements that it will determine
- are reviewed by the BBA as and when it considers appropriate.

4 The BBA has used due skill, care and diligence in preparing this Certificate, but no warranty is provided.

5 In issuing this Certificate the BBA is not responsible and is excluded from any liability to any company, firm, organisation or person, for any matters arising directly or indirectly from:

- the presence or absence of any patent, intellectual property or similar rights subsisting in the product or any other product
- the right of the Certificate holder to manufacture, supply, install, maintain or market the product
- actual installations of the product, including their nature, design, methods, performance, workmanship and maintenance
- any works and constructions in which the product is installed, including their nature, design, methods, performance, workmanship and maintenance
- any loss or damage, including personal injury, howsoever caused by the product, including its manufacture, supply, installation, use, maintenance and removal
- any claims by the manufacturer relating to UKCA marking and CE marking.

6 Any information relating to the manufacture, supply, installation, use, maintenance and removal of this product which is contained or referred to in this Certificate is the minimum required to be met when the product is manufactured, supplied, installed, used, maintained and removed. It does not purport in any way to restate the requirements of the Health and Safety at Work etc. Act 1974, or of any other statutory, common law or other duty which may exist at the date of issue or reissue of this Certificate; nor is conformity with such information to be taken as satisfying the requirements of the 1974 Act or of any statutory, common law or other duty of care.

British Board of Agrément

1st Floor Building 3
Croxley Park, Watford
Herts WD18 8YG

©2023

tel: 01923 665300
clientservices@bbacerts.co.uk
www.bbacerts.co.uk